

KEENCUT

Surface Mounted Lift & Hold Mechanism

For Javelin, Practik & Max Cutter Bars

GB INSTRUCTION MANUAL

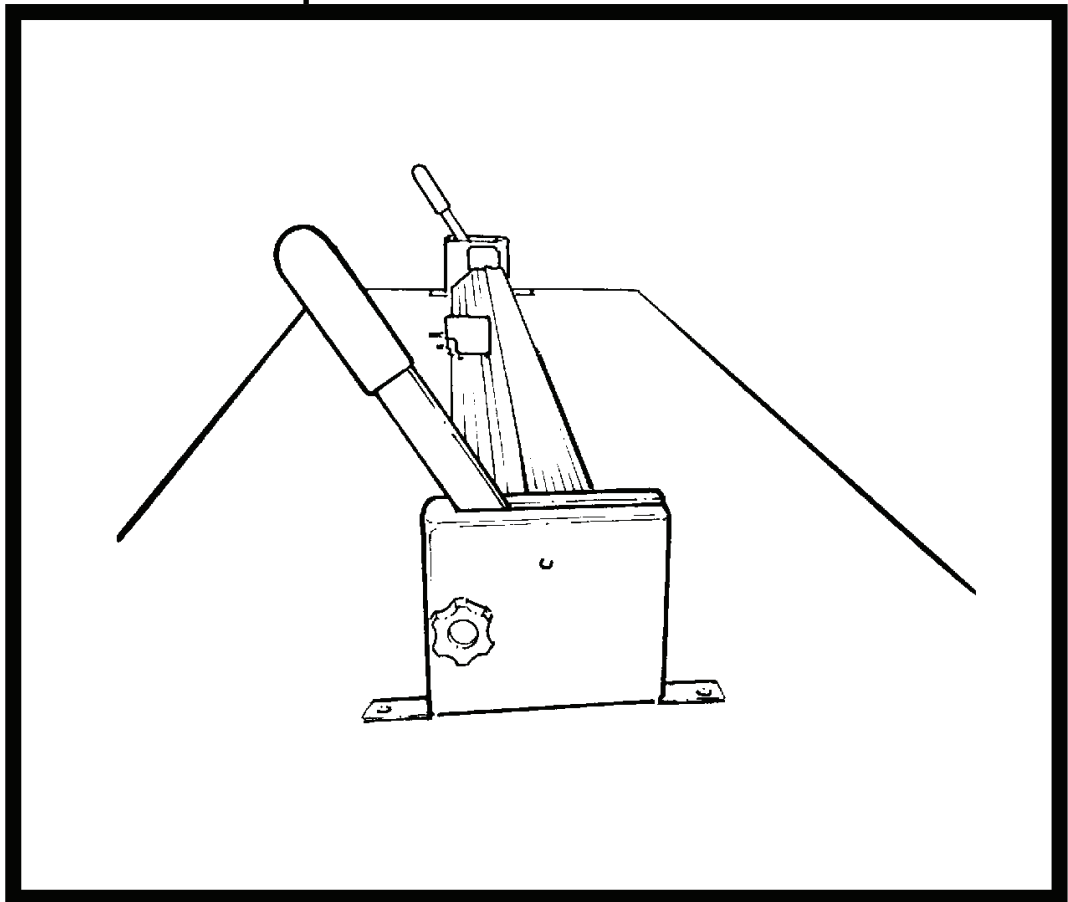

KEENCUT

THE WORLD'S FINEST CUTTING MACHINES

Surface Mounted Lift & Hold User Instructions

Safety & Preparation

Thank you for choosing the Surface Mounted Lift & Hold made by Keencut. Every effort has been made to bring you a superbly built product with the promise of many years of good service. In order to obtain maximum benefit from your machine please read these instructions carefully. For advice and assistance or replacement parts please contact your distributor or Keencut.

SAFETY

- The blade **must** be removed before moving, cleaning or lifting the Cutter Bar.
- Only lift or move the Cutter Bar using the finger grip on its top surface.
- Do not place your fingers near the blade when using the machine.



PREPARATION

It is essential that the surface being used to cut on is flat, if the surface is dished at any point then the material being cut may not be held in position firmly and will move sideways as the blade passes giving a curved cut. This is particularly important if thin or flexible materials are being cut.

Carry out the 'Paper Test' to check the area to be used for flatness :-

- Place the Cutter Bar in its operating position and pass a small piece of paper (about 25cm [10"] wide) under it at one end.
- Check the paper is gripped in position, if it is not take note of the position. If the paper is held in place move along the Cutter Bar gradually checking with the paper.
- When the whole length has been checked any adjustment or alteration to the bench should be made and the test carried out again until the paper is gripped for the full length of the Cutter Bar.

It is essential that the cutter is used on a flat surface to cut accurately.
A warped or bowed table top can result in a curved cut.

Surface Mounted Lift & Hold User Instructions

Positioning & Fixing to the Work Surface

POSITIONING THE LIFT & HOLDS

Fix the mechanisms to the work surface with the lifting tabs (T) facing inwards and set the correct distance between them according to the table below:-

Cutter Bar Type & Size								
Javelin/Praktik					Max			
1.0m (40")	1.5m (60")	2.0m (80")	2.5m (100")	3.0m (120")	3.5m (140")	4.0m (160")	4.5m (180")	5.0m (200")
115.5cm	165.5cm	215.5cm	265.5cm	315.5cm	370cm	420cm	470cm	520cm
45½"	65⅛"	84⅞"	104½"	124¼"	145⅝"	165⅜"	185"	78¾"

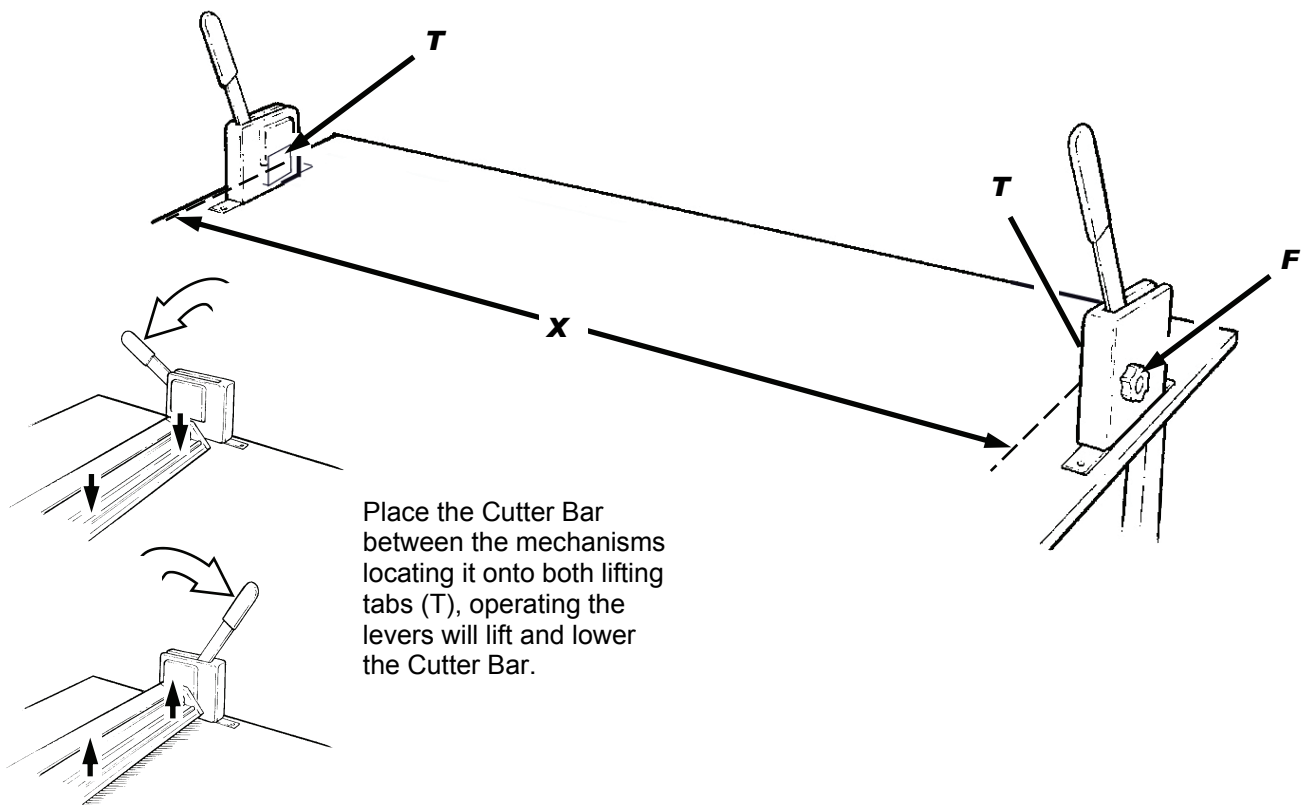
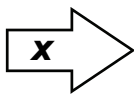

Loosen the friction knobs (F) on each of the mechanisms to allow the cutter to be raised, they can be adjusted to just hold the weight of the Cutter Bar. This enables the Cutter Bar to be held just above the surface of the material being cut for easy and accurate alignment.

As stated before, it is important to ensure the table surface in the area between the Lift & Hold Mechanisms is flat, **particularly when cutting thin films and paper**. If the table is not flat thin materials can deflect as the blade passes resulting in a curved cut, it is wise to repeat the 'paper test' at this stage.

A narrow groove can be machined in the table surface for the tip of the blade to run in. Otherwise cutting mats should be used to protect the table surface and prevent the blade tip being deflected whilst cutting.

Please refer to the Cutter Bar instruction manual for further guidance on cutting methods, a copy will be supplied with your Cutter Bar or it can be obtained from the keencut website.

Surface Mounted Lift & Hold User Instructions

Spare Parts

KEENCUT LIMITED

Tel: +44 (0) 1536 263158

Fax: +44 (0) 1536 204227

Email: sales@keencut.co.uk

Weldon South Ind. Estate,

Corby, Northants England NN18 8AZ.

KEENCUT INC. (North American Sales)

Toll Free: 1 800 240 5336

Tel: 1 (519) 652 0970

Fax: 1 (519) 652 0396

Email: northamericansales@keencut.com

#366 - 3560 Pine Grove Ave.

Port Huron, MI 48060, USA